

Features

- Active Mixer with Conversion Gain
- No External LO Driver Necessary
- Low LO Drive Level Required
- RF and LO Ports May Be Driven Single-ended
- Single 5-V Supply Voltage
- High LO-RF Isolation
- Broadband Resistive 50- Ω Impedances on All Three Ports
- Small SSO16 Package

Applications

- Digital Communication Systems
- 800 MHz to 1000 MHz Transceivers for Base Stations

Electrostatic sensitive device.
Observe precautions for handling.



Description

The T0780 is a high linearity active mixer which is manufactured using Atmel's advanced Silicon-Germanium (SiGe) technology. This mixer features a frequency range of 800 MHz to 1000 MHz. It operates from a single 5-V supply and provides 10 dB of conversion gain while requiring only 0 dBm input to the integrated LO driver. An IF amplifier is also included.

The T0780 incorporates internal matching on each RF, IF and LO port to enhance ease of use and to reduce the external components required. The RF and LO inputs can be driven differentially or single-ended.

Figure 1. Block Diagram

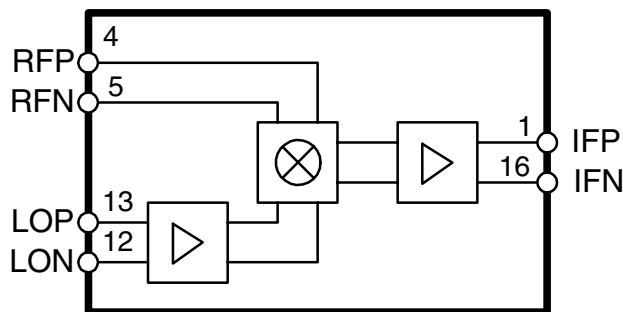

**800 MHz -
1000 MHz
High Linearity
SiGe Active
Receive Mixer**

T0780

Preliminary



Pin Configuration

Figure 2. Pinning SSOP16

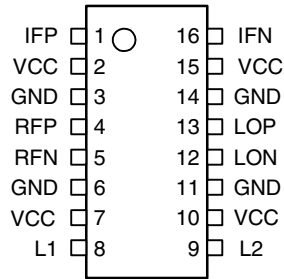

Pin Description

Pin	Symbol	Function
1	IFP	IF positive output
2	VCC	5-V power supply
3	GND	Ground
4	RFP	RF positive input
5	RFN	RF negative input
6	GND	Ground
7	VCC	5-V power supply
8	L1	External inductor terminal
9	L2	External inductor terminal
10	VCC	5-V power supply
11	GND	Ground
12	LON	Local oscillator, negative input
13	LOP	Local oscillator, positive input
14	GND	Ground
15	VCC	5-V power supply
16	IFN	IF negative output

Absolute Maximum Ratings

All voltages are referred to GND.

Parameters	Symbol	Value	Unit
Supply voltage	V_{CC}	5 to 5.5	V
LO input	LO_P LO_N	10	dBm
IF input	RF_P RF_N	15	dBm
Operating temperature	T_{OP}	-40 to +85	°C
Storage temperature	T_{stg}	-65 to +150	°C

Thermal Resistance

Parameters	Symbol	Value	Unit
Junction ambient	R_{thJA}	TBD	K/W
Junction case	R_{thJC}	46	°C/W

Electrical Characteristics

Test Conditions: $V_{CC} = +5\text{ V}$, $T_{amb} = +25^{\circ}\text{C}$; RF input: -20 dBm at 900 MHz; LO output: 0 dBm at 700 MHz

No.	Parameters	Test Conditions/Pins	Pin	Symbol	Min.	Typ.	Max.	Unit	Type *
1	AC Performance								
1.1	RF frequency range			f_{RF}	800		1000	MHz	B, C
1.11	LO frequency range			f_{LO}	500		1000	MHz	B, C
1.2	IF frequency range			F_{IF}	30	200	300	MHz	B, C
1.5	Conversion gain				7	10		dB	A
1.6	SSB noise figure					15	19	dB	D
1.3	Input IP3	RF1 = RF2 = -15 dBm/tone, 1 MHz spacing		IP3	15	19		dBm	D
1.4	Input P1dB				2	5		dBm	D
1.7	RF return loss	Matched to $50\ \Omega^{(1)}$				20		dB	D
1.8	LO return loss	Matched to $50\ \Omega^{(1)}$				20		dB	D
1.9	IF return loss	Matched to $50\ \Omega^{(1)}$				20		dB	D
1.10	LO drive	Matched to $50\ \Omega^{(1)}$			-3	0	+3	dBm	D
2	Isolation Performance								
2.1	Leakage (LO-RF)	Single-ended configuration				-40	-35	dBm	D
2.2	Leakage (LO-IF)	Single-ended configuration				-26	-20	dBm	D
2.3	Leakage (RF-IF)	Single-ended configuration				-40	-35	dBm	D
3	Miscellaneous								
3.1	Supply voltage			V_{CC}	4.75	5	5.25	V	A
3.1	Supply current			I_{CC}		160	180	mA	A

*) Type means: A = 100% tested, B = 100% correlation tested, C = Characterized on samples, D = Design parameter

Notes: 1. The return losses shown were measured with the T0780 mounted on Atmel's FR4 evaluation boards using standard matching practices as indicated on the application schematic page herein. Users following the RF, LO and IF matching guidelines will achieve similar performance.

Typical Device Performance

Figure 3. Conversion Gain versus Temperature

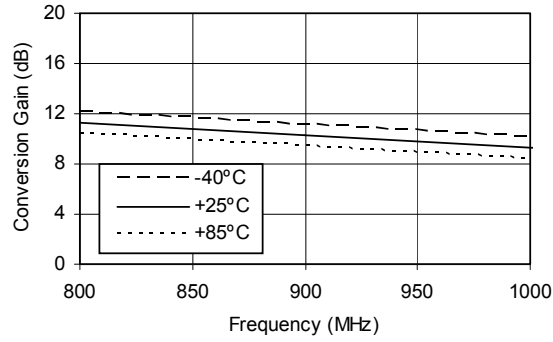

Figure 4. Conversion Gain versus LO Drive, $T_{amb} = 25^{\circ}\text{C}$

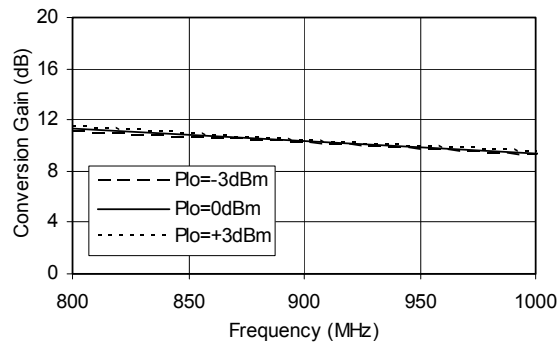

Figure 5. Leakages, Plo = 0 dBm, Prf = -20 dBm, Single-ended Configuration

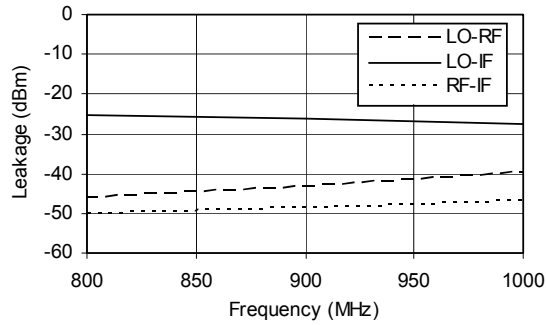

Figure 6. Input IP3 versus Temperature

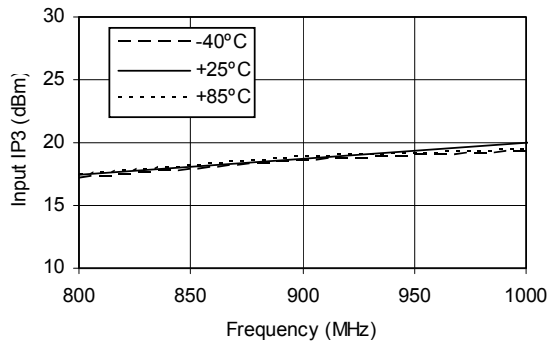

Figure 7. Input IP3 versus LO Drive, $T_{amb} = 25^{\circ}\text{C}$

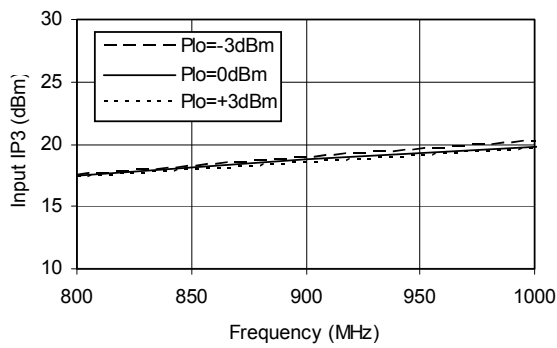

Figure 8. Noise Figure versus Temperature, Plo = 0 dBm

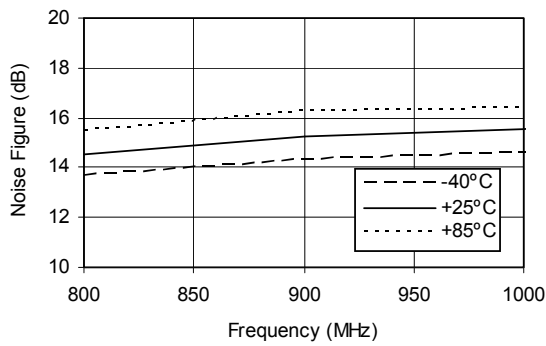

Figure 9. RF and LO Return Loss $T_{amb} = 25^{\circ}\text{C}$

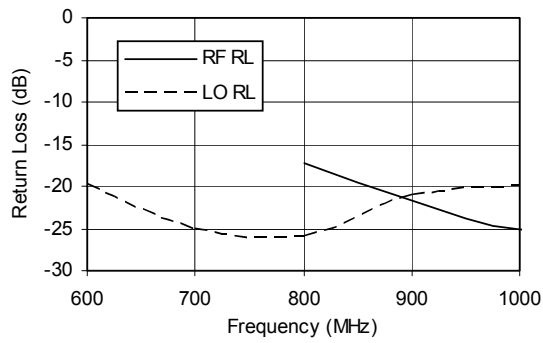

Figure 10. IF Return Loss $T_{amb} = 25^{\circ}\text{C}$

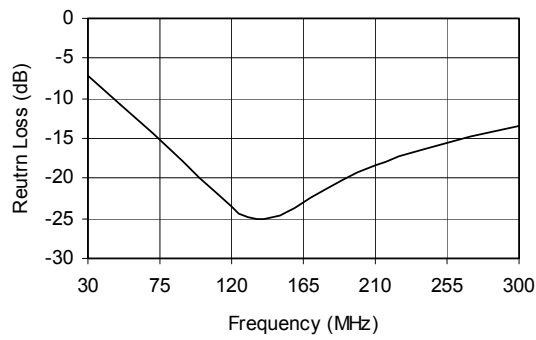

Figure 11. Input P1dB versus Temperature, $P_{lo} = 0 \text{ dBm}$

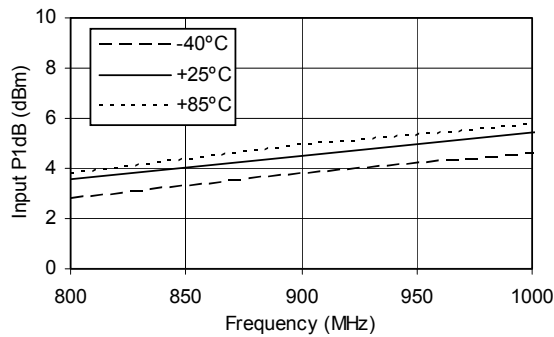

Figure 12. Input P1dB versus LO Drive, $T_{amb} = 25^{\circ}\text{C}$

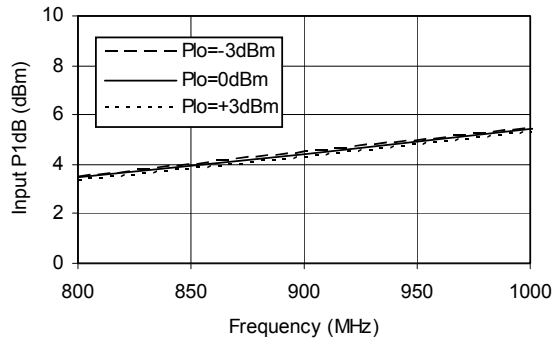
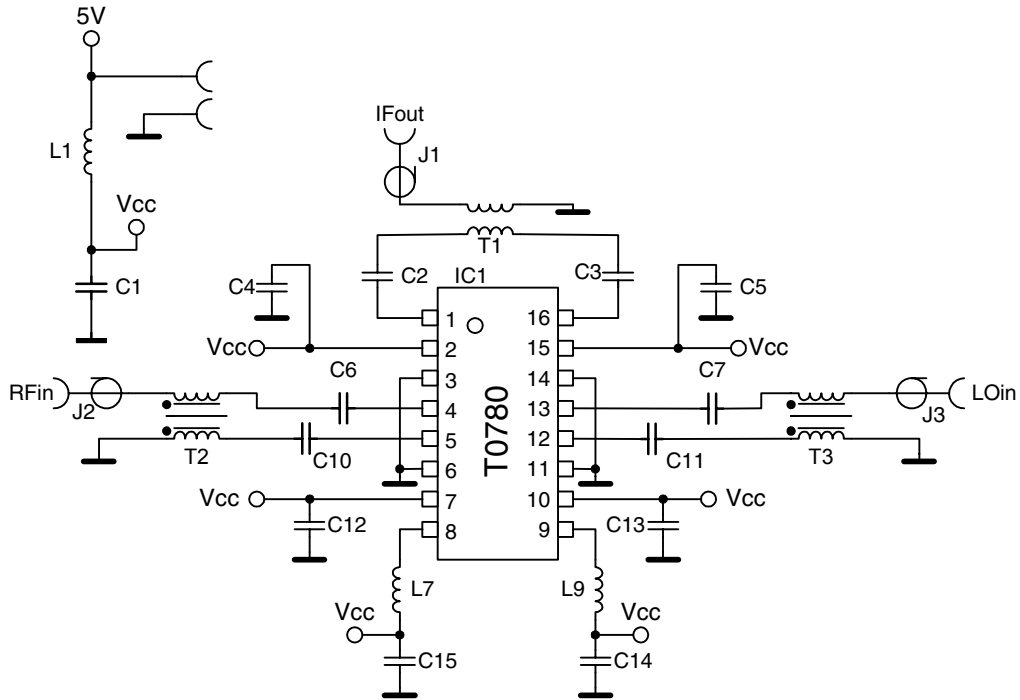

Figure 13. Demo Test Board Schematic



Bill of Material

Component Designator	Value	Vendor	Part Number	Description
IC1		Atmel	T0780	SiGe receiver mixer
J1, J2, J3		Johnson Components™	742-0711-841	SMA connector, end launch with tab, for 1.07 mm board
T1	1:1	Mini-Circuits®	TC1-1	IF transformer
L1	1 μ H	Würth Elektronik®	74476401	Inductor, 1210 footprint, minimum 200 mA rating
L7, L9	see Table 1	Würth Elektronik	744786110	Inductor, 0603 footprint, high Q series
C4, C5, C12, C13	27 pF	Vishay®	VJ0402A 270JXXA_	Capacitor, 0402 footprint
C14, C15	100 pF	Vishay	VJ0402A101JXXA_	Capacitor, 0402 footprint
C2, C3	120 pF	Vishay	VJ0402A121JXXA_	Capacitor, 0402 footprint
C1	10 μ F	KEMET®	T491A106_010AS	Tantal chip capacitor, size A
T2, T3	1:1	Panasonic®	EHF-FD1618	RF transformer
C6, C10	15 pF	Vishay	VJ0402A150JXXA_	Capacitor, 402 footprint
C7, C11	18 pF	Vishay	VJ0402A180JXXA_	Capacitor, 402 footprint

The T0780 utilizes an IF tank circuit to maximize performance across the entire IF bandwidth. The off-chip inductors L7 and L9 resonate with an on-chip capacitor (4 pF) to provide IF tunability. Therefore, L7 and L9 must be selected such that the resonance occurs at the desired IF.

The following table provides the inductor values required on the evaluation board for some common intermediate frequencies. By default, all evaluation boards are shipped with L7 = L9 = 100 nH, resulting in a 200 MHz resonant IF.

Table 1. IF Tank Circuit

IF (MHz) Typical	L7, L9 (nH)	Würth Elektronik Part Number
70	680	744780680
150	150	74478625
200	100	744786110
300	39	744786131

Figure 14. Demo Test Board (Fully Assembled PCB)

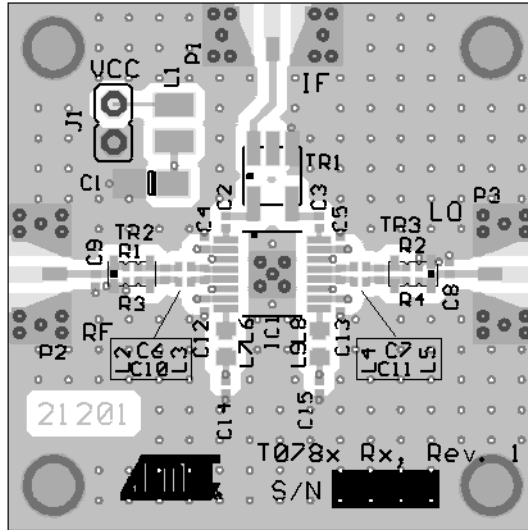
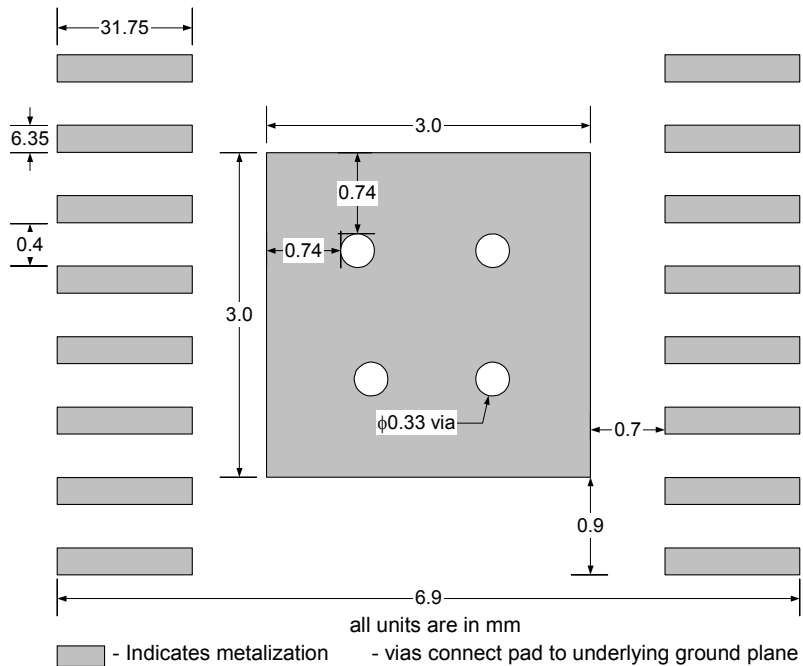

Figure 15. Recommended Package Footprint

In order to avoid soldering problems, plugging of the ground vias under the heat slug is recommended!



Remark: heatslug must be soldered to GND.

Ordering Information

Extended Type Number	Package	Remarks
T0780-6C	SSOP16	–

Package Information

Package: SSOP16
 (acc. JEDEC SMALL OUTLINE No. MO-153)
 Dimensions in mm

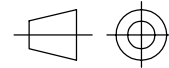
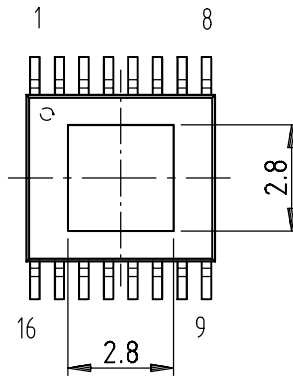

technical drawings
 according to DIN
 specifications

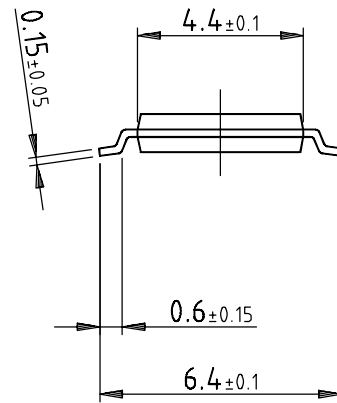
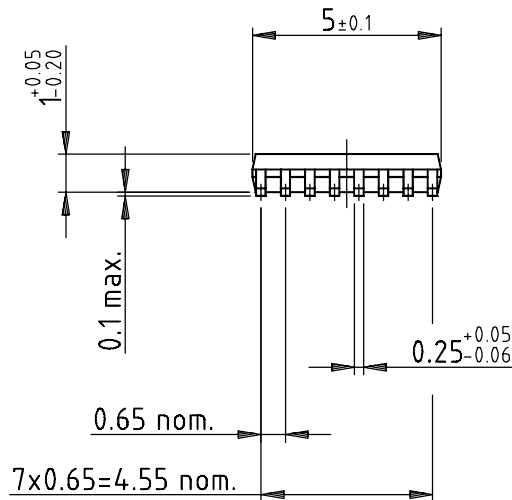

Drawing-No.: 6.543-5079.01-4
 Issue: 1; 10.07.01



Atmel Corporation

2325 Orchard Parkway
San Jose, CA 95131, USA
Tel: 1(408) 441-0311
Fax: 1(408) 487-2600

Regional Headquarters

Europe

Atmel Sarl
Route des Arsenalux 41
Case Postale 80
CH-1705 Fribourg
Switzerland
Tel: (41) 26-426-5555
Fax: (41) 26-426-5500

Asia

Room 1219
Chinachem Golden Plaza
77 Mody Road Tsimshatsui
East Kowloon
Hong Kong
Tel: (852) 2721-9778
Fax: (852) 2722-1369

Japan

9F, Tonetsu Shinkawa Bldg.
1-24-8 Shinkawa
Chuo-ku, Tokyo 104-0033
Japan
Tel: (81) 3-3523-3551
Fax: (81) 3-3523-7581

Atmel Operations

Memory

2325 Orchard Parkway
San Jose, CA 95131, USA
Tel: 1(408) 441-0311
Fax: 1(408) 436-4314

Microcontrollers

2325 Orchard Parkway
San Jose, CA 95131, USA
Tel: 1(408) 441-0311
Fax: 1(408) 436-4314

La Chantrerie
BP 70602
44306 Nantes Cedex 3, France
Tel: (33) 2-40-18-18-18
Fax: (33) 2-40-18-19-60

ASIC/ASSP/Smart Cards

Zone Industrielle
13106 Rousset Cedex, France
Tel: (33) 4-42-53-60-00
Fax: (33) 4-42-53-60-01

1150 East Cheyenne Mtn. Blvd.
Colorado Springs, CO 80906, USA
Tel: 1(719) 576-3300
Fax: 1(719) 540-1759

Scottish Enterprise Technology Park
Maxwell Building
East Kilbride G75 0QR, Scotland
Tel: (44) 1355-803-000
Fax: (44) 1355-242-743

RF/Automotive

Theresienstrasse 2
Postfach 3535
74025 Heilbronn, Germany
Tel: (49) 71-31-67-0
Fax: (49) 71-31-67-2340

1150 East Cheyenne Mtn. Blvd.
Colorado Springs, CO 80906, USA
Tel: 1(719) 576-3300
Fax: 1(719) 540-1759

Biometrics/Imaging/Hi-Rel MPU/ High Speed Converters/RF Datacom

Avenue de Rochepleine
BP 123
38521 Saint-Egreve Cedex, France
Tel: (33) 4-76-58-30-00
Fax: (33) 4-76-58-34-80

Literature Requests

www.atmel.com/literature

Disclaimer: Atmel Corporation makes no warranty for the use of its products, other than those expressly contained in the Company's standard warranty which is detailed in Atmel's Terms and Conditions located on the Company's web site. The Company assumes no responsibility for any errors which may appear in this document, reserves the right to change devices or specifications detailed herein at any time without notice, and does not make any commitment to update the information contained herein. No licenses to patents or other intellectual property of Atmel are granted by the Company in connection with the sale of Atmel products, expressly or by implication. Atmel's products are not authorized for use as critical components in life support devices or systems.

© Atmel Corporation 2003. All rights reserved. Atmel® and combinations thereof are the registered trademarks of Atmel Corporation or its subsidiaries, Johnson Components™ is a trademark of Emerson Electric Co., Würth Elektronik® is a registered trademark of Adolf Würth GmbH & Co. KG, Panasonic® is a registered trademark of Matsushita Electric Industrial Co., Ltd., Mini-Circuits® is a registered trademark of Scientific Components, Vishay® is a registered trademark of Vishay Intertechnology, Inc., KEMET® is a registered trademark of KRC Trade Corporation. Other terms and product names may be the trademarks of others.



Printed on recycled paper.